

HAC-LAN433 Series

Data RF Module

Version 1.1a



SHENZHEN HAC TELECOM TECHNOLOGY CO., LTD

Address : 3rd Area, 19th Fl, Tower A, HaiSong Building, Tai Ran 9th Rd,
Futian, ShenZhen, China.

Tel : +86-755-23981078

Fax : +86-755-23981007

E-mail : webmaster@haccomm.com

Website : <http://www.haccomm.com>



Catalogue

I. Features of HAC-LAN433 Series.....	3
II. Applications of HAC-LAN433 Series.....	4
III. The Naming methods for HAC-LAN433 Series.....	4
IV. How to use HAC-LAN433 Series	4
V. Networking Application of HAC-LAN433 Series	8
VI. Technical specification of HAC-LAN433 Series	8
VII. The fittings for HAC-LAN433 Series	9

I. Features of HAC-LAN433 Series

1. The standard transmitting power is 1W (30dBm).

The frequency covers from 427MHz to 436MHz. Users can customize the modules with other UHF/VHF frequency band.

2. The real narrowband and high-speed technology.

The bandwidth for signal is 12.5KHz or 25KHz. It is high efficient use for spectrum and high anti-interference. The maximum effective baud rate is up to 19200bps.

3. High anti-interference and Low BER (Bit error Rate)

Based on the GFSK or RC2FSK modulation, the high-efficiency forward error correction channel encoding technology is used to enhance data's resistance to both transient interference and random interference, and the actual bit error rate of $10^{-5} \sim 10^{-6}$ can be achieved when channel bit error rate is 10^{-3} . The highest sensitivity is -122dBm @ 1200bps.

4. Long Transmission Distance

Within the visible range, when the height of antenna is higher than 2m, the longest reliable transmission distance is more than 5000m.

5. It is professional high-frequency circuit design. It can meet the requests of EMC testing.

Using high-quality devices and TCXO crystal with high frequency stability, the working temperature is from -40 to +80 . It is industrial grade, high integration and low failure rate.

6. Transparent data transmission

Transparent data interface is used for meeting any standard user protocols. Any false data generated by noise can be filtrated automatically (what has been received is exactly what has been transmitted).

7. Multi-channels

HAC-LAN433 standard module can offer 16 channels. It can be extended for 64 channels.

8. Three connection methods

Using conversion chip for industrial serial port, HAC-LAN433S offers standard RS232, RS485, TTL/UART and special PHOENIX power data connection interface.

9. Optional data baud rate and data format

With optional interface baud rate: 1200/2400/4800/9600bps and 8N1/8E1 data format (set by user), the transceiver can support large data package that is no more than 600Bytes.

10. Intelligent data control and no any complicated transmission programs required

No any excessive programs about RF is required. It is just like the manipulation of RS485



interface, you only need to transmit and receive the data through interface. HAC-LAN433 can finish the transmit/receive conversion in the air automatically.

11. Compatibility

HAC-LAN433 can be compatible with HAC-UAN433 under the same baud rate and the same frequency to meet many types of communication assembled methods.

II. Applications of HAC-LAN433 Series

- ? The matching for export products.
- ? Army railway and police communication sets.
- ? Special data transmitting system for railway, electric power and oil fields.
- ? Industrial remote control and telemetry, automatic data collection system for factory.
- ? Industrial scene with high reliability and strong electromagnetic interference.

III. The Naming methods for HAC-LAN433 Series

The type naming method for HAC-LAN433X is shown as follow:

‘HAC’- the title of manufacturer: Shenzhen HAC Telecom Technology Co., Ltd

‘L’ - Low power, the transmission power is no more than 30dBm

‘A’ - The name of products series

‘N’- The narrowband products

‘433’ – The working frequency band, the center frequency of the working frequency band

‘S’ – The type name of this series: S is default standard type

H is 19200bps high speed type

IV. How to use HAC-LAN433 Series

HAC-LAN433 offers three interface methods which include RS-232, RS-485 and UART/TTL level interface. It can connect with PC, RS232/RS485 devices, SCM or other UART components directly. The using method is as follow:

1. Power supply

The voltage range of power supply is +11.0~15.0V DC. Please use better ripple factor. If HAC-LAN433 needs to share power supply and ground with other equipment, please use single point access method. If possible, the signal is insulated by optocoupler, the power

supply is insulated by transformer, so that it can get the best communication results, and it is steady and reliable.

2. The definition of connector

- a. HAC-LAN433 offers one 10-pin connector (PHOENIX). Their definitions and Connection methods with terminals are shown in Table 1.

Table 1: Pin Definitions and connection methods

Pin	Definition	Instruction	Level	Connection with terminal	Remarks
1	GND	Ground			
2	VCC	Power supply		Input	+11.0~15.0VDC
3	RxD_TTL	UART/Rx	TTL	Input	0 or 5.0V
4	TxD_TTL	UART/Tx	TTL	Output	0 or 5.0V
5	RxD_RS232	RxD	RS-232	Input	±5.0~9.0V
6	TxD_RS232	TxD	RS-232	Output	±5.0~9.0V
7	A_RS485	A	RS-485	Input/ Output	0 ~ 5.0V
8	B_RS485	B	RS-485	Input/ Output	0 ~ 5.0V
9	NC			Not connect	Unconnected
10	Reset	Negative reset	TTL	Input	Negative pulse reset

Note: The reset negative pulse must be more than 10 μ A.

- b. The connection schematic diagram between HAC-LAN433 and terminal.

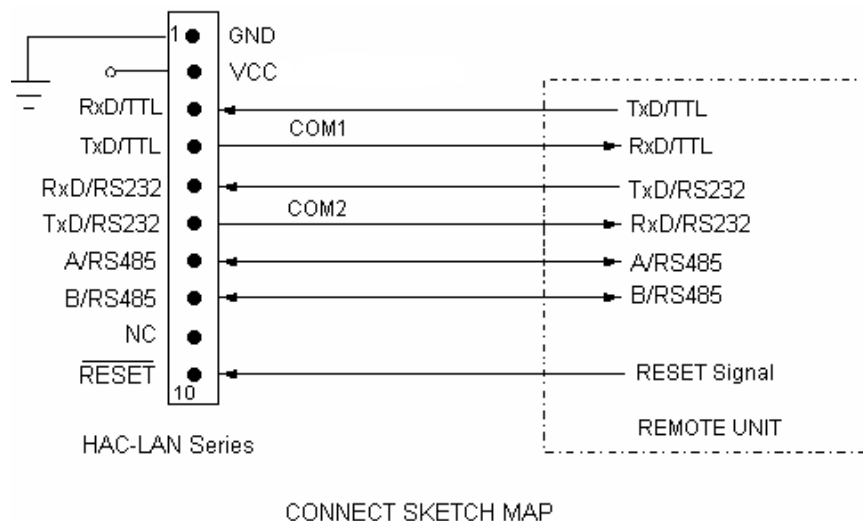

3. Setting the baud rate, interface and data format

Before placing the order, users should select the type of LAN433 according to their requests. Before using the module, users should need to make some simple configurations to confirm the channel frequency, interface mode, baud rate, data format and so on according to your needs. There is a group of 8-bit DIP switch in HAC-LAN433S, defined as SW87654321 respectively. If the DIP switch is in the ON position, it means '0'. If the DIP switch is in the OFF position, it means '1', the configuration is shown as Table 2.

Table 2: The definition of SW switch

NO.	Name	Function	Remarks
SW8 SW7 SW6 SW5	F_S	Channel setting	SW8765= 0000 (0 channel) SW8765= 1111 (15 channel) The four DIP switches are used to decide the channels. There are 16 channels to choose. SW8 is the high bit.
SW4	V_S		SW4=0: 8n1 (No parity) ; SW4=1: 8e1 (Even parity)
SW3 SW2	SP_S	Communication baud rate setting	SW32=00: 1200bps ; SW32=01: 2400bps ; SW32=10: 4800bps ; SW32=11: 9600bps
SW1	P_S	Choose the transmitting power	SW1=0: 500mW ; SW1=1: 1W ; (default 12V) SW1=0: 200mW ; SW1=1: 500W ; (customize 5V)

Note 1: The air baud rate is equal to the interface baud rate.

Note 2: Any changes of the switches except SW1 are effective when the modules have been electrified or reset.

Note 3: The SW2 and SW3 switches are not effective in the LAN433H type.

4. Channel configuration for HAC-LAN433S:

HAC-LAN433S offers 16 channels. User can use four DIP switches to set the channel, and the channel frequency is as follow table3:

Table 3: Channel frequency

Channel No	Frequency	Channel No	Frequency	Channel No	Frequency	Channel No	Frequency
0	427.000	4	429.400	8	431.800	12	434.200
1	427.600	5	430.000	9	432.400	13	434.800
2	428.200	6	430.600	10	433.000	14	435.400
3	428.800	7	431.200	11	433.600	15	436.000

5. Power and sending/receiving data indicator

Power indicator light D1 (DATA OUT): After the module has been electrified, the red light is bright, it means the power has been normal access.

Sending/receiving indicator light D2 (DATA IN and DATA OUT): Two colors LED light.

When the module receives the data from air and outputs the data to external equipments through serial port, the green light flicker. When the module receives the data from serial port, it is on the state of transmitting, the red light flicker.

6. Dimension sketch map (Unit: mm):

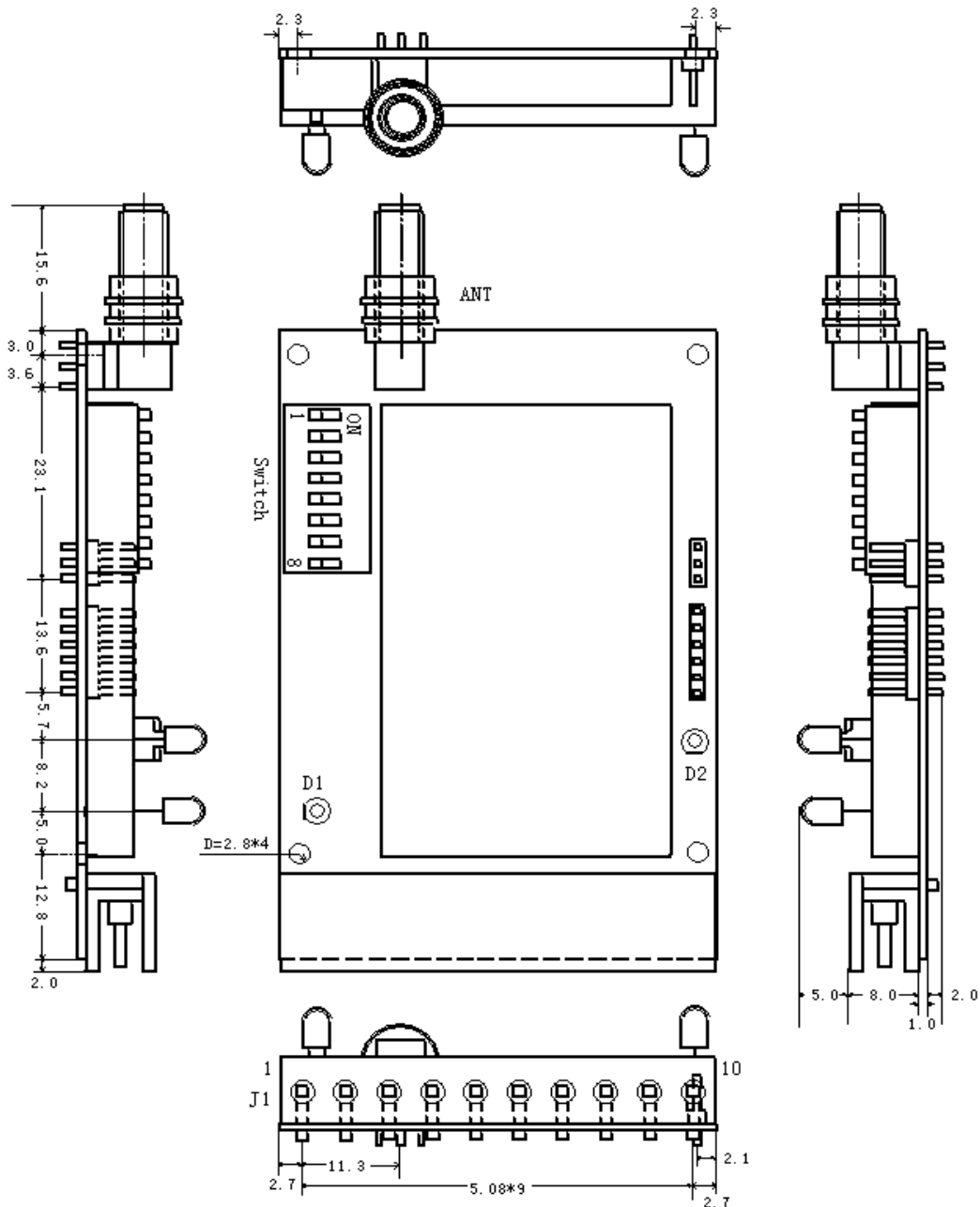

V. Networking Application of HAC-LAN433 Series

The communication channel of HAC-LAN433 is half duplex, which is mostly suitable for the communication mode of point to multi-point. Under this mode, one master station must be set, and all of the rest are slave stations with a unique address. The coordination of communication is controlled by master station that uses data frames containing address code to transmit data or command. All of slave stations will receive the data and command and compare the received address code with local address code. If they are different, the data will be dismissed without any response. If they are same, it means the data is sent to the local. Slave station will make different responses according to the transmitted data or command and send back the data as response. All these jobs must be performed by upper level protocol, which will assure that there is only one transmitter in transmitting mode in the communication network at any transient moment so as to avoid the cross-interference.

HAC-LAN433 transceivers can also be used for point-to-point communication with easier operation. For the programming of serial port, all you have to do is to remember that its communication mode is half duplex and always to observe the time sequence of come-and-go for receiving and transmitting.

VI. Technical specification of HAC-LAN433 Series

Frequency range	: 427~436MHz
Frequency Stability	: ± 2.5 PPm
Modulation mode	: GFSK/RC2FSK
Channel interval	: 300KHz
Channel bandwidth	: 25KHz
Channel	: 16
Transmission power	: 500mW/1W (optional)
Receiving sensitivity	: -122dBm @ 1200bps (1% BER)
RF data rate	: 1200/2400/4330/9600bps (optional), 19200bps (customize)
Interface data format	: 8E1/8N1 (optional)
Temperature	: -40 ~80 (Industry)
Power supply	: +11.0 ~ 15.0VDC
Transmitting current	: 350mA (the transmission power is 27dBm) 500mA (the transmission power is 30dBm)
Receiving current	: 50mA

Humidity : 10%~90% relative humidity without condensation
Dimension : 76 mm X51.2mm x16mm

Note: The sleep current of HAC-LAN433S is a little large, so we recommend that you don't use the sleep function. Our standard products don't have the sleep function.

VII. The fittings for HAC-LAN433 Series

1. Standard configuration

- a. The standard antenna for HAC-LAN433 is a 10cm helical antenna called HAC-LX433-10-ZSMA.



- b. Fixing end for connection



If the users have difficulties in fixing the products because of the dimension, you can order the products without the fixing end.

2. Other optional antenna

HAC-LAN433 can be used with SMA antenna joint to meet the antenna requests of users. Users need to use the 50 impedance and the working frequency of antenna must be the same as the module. If you order outdoor omni-directional antenna or directional antenna with high gain, it will increase the coverage greatly. In addition, the order antenna is required to stand 1w transmitting power. And the V.S.W.R is less than 1.5.

- a. Users can customize the little magnetic antenna called HAC-XP433S-300H-SMA with high performance price ratio. It is an antenna with 300cm antenna feeder. It is high gain and convenient to installation.



b. If users use outdoor omni-directional antenna or directional antenna with high gain, it will enhance the coverage of the module greatly.