



HAC-HM Series Data Radios





Catalogue

I. Features of HAC-HM Series.....	3
II. Application of HAC-HM Series	4
III. How to use HAC-HM Series.....	4
IV. Networking Application of HAC-HM Series	11
. Technical specification of HAC-HM Series	12
. Description of type	15
VII. Fittings.....	12



I. Features of HAC-HM Series

1. Large power transmission with the transmission power of 2W and 5W selectable.
2. The carrier frequency is 429~437MHz.
3. High receiving sensitivity, the maximum receiving sensitivity is -120dBm@1200bps.
4. High anti-interference and low BER(Bit Error Rate)

Based on the GFSK modulation mode, the high-efficiency forward error correction channel encoding technology is used to enhance data's resistance to both burst interference and random interference and the actual bit error rate of $10^{-5} \sim 10^{-6}$ can be achieved when channel bit error rate is 10^{-2} .

5. Long transmission distance

Within the range of visibility, when the 10dBi antenna height is more than 10m, the reliable transmission distance for the module with 5W is more than 20km (BER= 10^{-2} /1200bps).

Within the range of visibility, when the 5.5dBi antenna height is more than 2m, the reliable transmission distance for the module with 5W is more than 10km (BER= 10^{-2} /1200bps).

6. Industry

By using the high quality components and high reliable crystal, the working temperature is from -40 to +80 .

7. Transparent data transmission

Transparent data interface is offered to suit any standard or nonstandard user protocol. Any false data generated in the air can be filtrated automatically (What has been received is exactly what has been transmitted).

8. Multi-channel

The standard HAC-HM configuration provides 8 channels. If the user needs, it can be extended to 16/32 channels, meeting the multiple communication combination mode of the user.

9. Three interface modes(TTL、RS-232、RS-485).

10. Large data buffer zone

The interface baud rate is 1200/2400/4800/9600/19200/38400bps with format of 8N1/8E1 and user self-definition.

11. Intelligent data control and the user doesn't need to prepare excessive programs

Even for semi duplex communication, the user doesn't need to prepare excessive programs, only receiving/transmitting the data from the interface. HAC-HM will automatically complete



the other operations, such as transmission/receiving conversion in the air.

- HAC-HM can indicate the intensity of magnetic field, the power source and the transmission and receive of data.

II. Application of HAC-HM Series

HAC-HM series is suitable for:

- * Communication for army and police
- * Communication for railway and electric power network
- * Remote control and telemetry, automatic data collecting system

III. How to use HAC-HM Series

HAC-HM series data radios provides three interface modes including standard RS-232, RS-485 and UART/TTL levels allowing direct connection with computer, user's RS-485 device, monolithic processor and other UART components for application.

1. Power supply

HAC-HM uses DC power supply with voltage of +12~16V and 1.5A current. We suggest not use the switch power. But if you must, please pay more attention to the interference of switch pulse on the module, and you'd better use the switch power supply with high frequency. Of course the linearity power is better. If you can separate module from other equipment by optocoupler, meanwhile separate module power from other equipment power by linearity power, the communication quality will be better.

2. Definition of HAC-HM connector

HAC-HM can supply one 3P power connector (JP1) and 14-pin connector (JP2), this is the version A. Or 8-pin (JP2) connector and 6-bit switches, this is the version B. And their definitions as well as connection method for terminals are shown in Table 1 and Table 2.

Table 1: Definition of 3P power supply interface pins and connection method

Pin No.	Pin Name	Level	Connected to the terminal Description	Remarks
1	PW_EN	ON/OFF	ON: Unconnected or connect with VCC, OFF: connect with ground	
2	VCC	+	DC12~16V@1.5A	
3	GND	-	Ground	

Table 2: Definition of JP2 interface and connection method

Pin No	Pin Name	Description	Level	Connected to the terminal	Remarks



1	TxD1	The TxD of RS-232	RS-232	RxD	Connect to the 2 nd pin of computer
2	RxD1	The RxD of RS-232	RS-232	TxD	Connect to the 3 rd pin of computer
3	SGND	Signal ground			Connect to the 5 th pin of computer
4	TxD2	TxD of TTL	TTL	RxD	
5	RxD2	RxD of TTL	TTL	TxD	
6	A	The A of RS-485	RS-485	A	
7	B	The B of RS-485	RS-485	B	
8	RESET	Reset signal (input)	TTL	Negative pulse for activation, unconnected means high level.	
9/SW1	Baud_SEL	Baud rate selection	TTL	Unconnected means 1 (high level), SW1=OFF means 1.	
10/SW2	Verify_SEL	Parity selection	TTL	Unconnected means 1 (high level), SW2=OFF means 1.	
11/SW3	Power_SEL	Power selection	TTL	Unconnected means 1 (high level), SW3=OFF means 1.	
12/SW4	CH2_SEL	Channel selection	TTL	Unconnected means 1 (high level), SW4=OFF means 1.	
13/SW5	CH1_SEL	Channel selection	TTL	Unconnected means 1 (high level), SW5=OFF means 1.	
14/SW6	CH0_SEL	Channel selection	TTL	Unconnected means 1 (high level), SW6=OFF means 1.	

3. Setting of baud rate, parity, power and channel:

Before using HAC-HM, the user needs to make simple configuration based on its own needs to confirm the baud rate, parity, power and channel.

a. Baud rate selection:

HAC-HM is separated into three kinds, HM12 is low speed, HM96 is middle speed, HM384 is high speed. Every model has two baud rate, it is selected by JP2_9/SW1.

Table 3: Baud rate selection



Model	JP2_9/SW1	Baud rate
HAC-HM12	1	1200bps
	0	2400bps
HAC-HM96	1	9600bps
	0	4800bps
HAC-HM384	1	38400bps
	0	19200bps

b. Parity selection:

HAC-HM can support no-parity or even parity modes, i.e. 8N1/8E1. It can choose parity mode through the JP2_10/SW2:

Table 4: Parity selection

JP2_10/SW2	Parity mode
1	No-parity (8N1)
0	Even-parity (8E1)

c. Power selection:

HAC-HM can offer two kinds of output power, one is 2W (33dBm), the other one is 5W (37dBm). It is selected by JP2_11/SW3.

Table 5: Output power selection

JP2_11/SW3	Output power
1	5W (37dBm)
0	2W (33dBm)

d. Channel configuration:

There are 8 channel options for HM module, and the user can choose to use 0-7 channels.

The default channel is 7 channel, JP2_12 13 14/SW4 5 6=111(7), frequency is 433.926MHZ

The standard frequency is a designative one which can be chosen by the customer.

Table 6: Corresponding frequency points of 0~7 channels

Channel No.	Frequency
JP2_12 13 14/SW4 5 6=000(0)	429.1548 MHz
JP2_12 13 14/SW4 5 6=001(1)	430.2000 MHz
JP2_12 13 14/SW4 5 6=010(2)	431.4288 MHz
JP2_12 13 14/SW4 5 6=011(3)	432.3250 MHz

JP2_12 13 14/SW4 5 6=100(4)	433.1580 MHz
JP2_12 13 14/SW4 5 6=101(5)	435.6060 MHz
JP2_12 13 14/SW4 5 6=110(6)	436.9884 MHz
JP2_12 13 14/SW4 5 6=111(7)	433.9260 MHz

4. The indicator of the magnetic field intensity, power supply and the transmission of data;
 There are some LED indicators, the state definition are shown as follow:

Table 7: State of the LED indicator

LED	LED state
PWR_LED	Red LED is on - - power on (PW_EN is unconnected or connect with VCC.)
RDI_LED	Yellow LED is on - - receiving data
TXI_LED	Green LED is on - - transmitting data
RSI_LED	Green LED is on - - signal intensity of receiving, the LED is more bright, the signal is more strong
PEI_LED	Red LED- - Reservation

5. The attentions of data transmission

a. The delay time (tc) of conversion between transmitting and receiving is less than 1ms.

Timing diagram:

HAC-HM

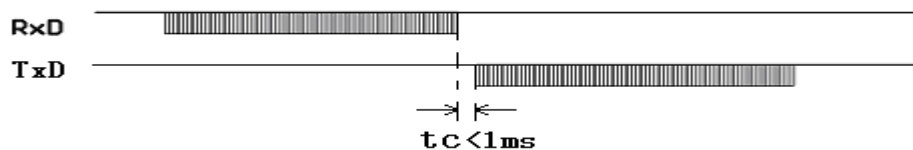

b. The delay time of transceivers between the first bit sent by TxD to the first bit received by RxD.

Due to a data processing will be made on user’s data by HAC-HM transceiver using FEC (Forward Error Correction) or other correction algorithm, when RxD of a HAC-HM transceiver ‘A’ receives the data, then transmits it, the other one transceiver ‘B’ will have a delay (ts) to receive and transmit by TxD. Different RF data rate causes different delay time.

Please see the specific delay time below:

Baud rate (bps)	Delay ts (ms)	Baud rate (bps)	Delay ts (ms)
--------------------------	------------------------	--------------------------	------------------------

1200	128	9600	16
2400	64	19200	8
4800	32	38400	4

Time diagram:

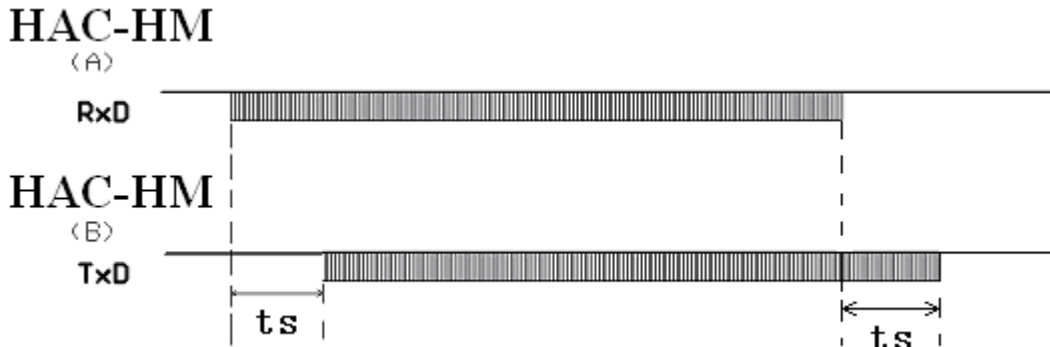

c. Error dealing procedure:

To enhance the reliability and stability of user’s systems, a verify bit or a Cyclic Redundancy Check (CRC) mode is highly recommended to resent the wrong information while using HAC-HM series modules.

d. Large-number data transmission

In theory, when the interface data rate is faster than the RF data rate, HAC-HM transceivers can send unlimited-long data package, but any long packages more than 120B are not recommended. The length of each package should be between 60~100B. We also recommend user to resent the wrong information using Automatic Error Request Equipment (ARQ).

The analyzing as below:

What if the actual transmission BER (Bit Error Rate) is 10^{-4} , 1 packet with 1KB data, which is about 10-thousand bits, is sent, theoretically, at least 1 bit will be received wrongly, then the 1KB information will never be received correctly.

But if we package the data into 10 packets with 100B for each, when all 10 packets are sent, there will be only 1 packet wrong according to this probability. After that, resend this wrong packet using ARQ mode. So by resending one more packet and the efficiency rate is reduced 10%, all data will be absolutely received correctly.

6. Dimension diagram (Unit: mm):

The dimension diagram below is the factory set default of HAC-HM transceiver. Other required smaller sizes and different shapes can also be provided.

Version A

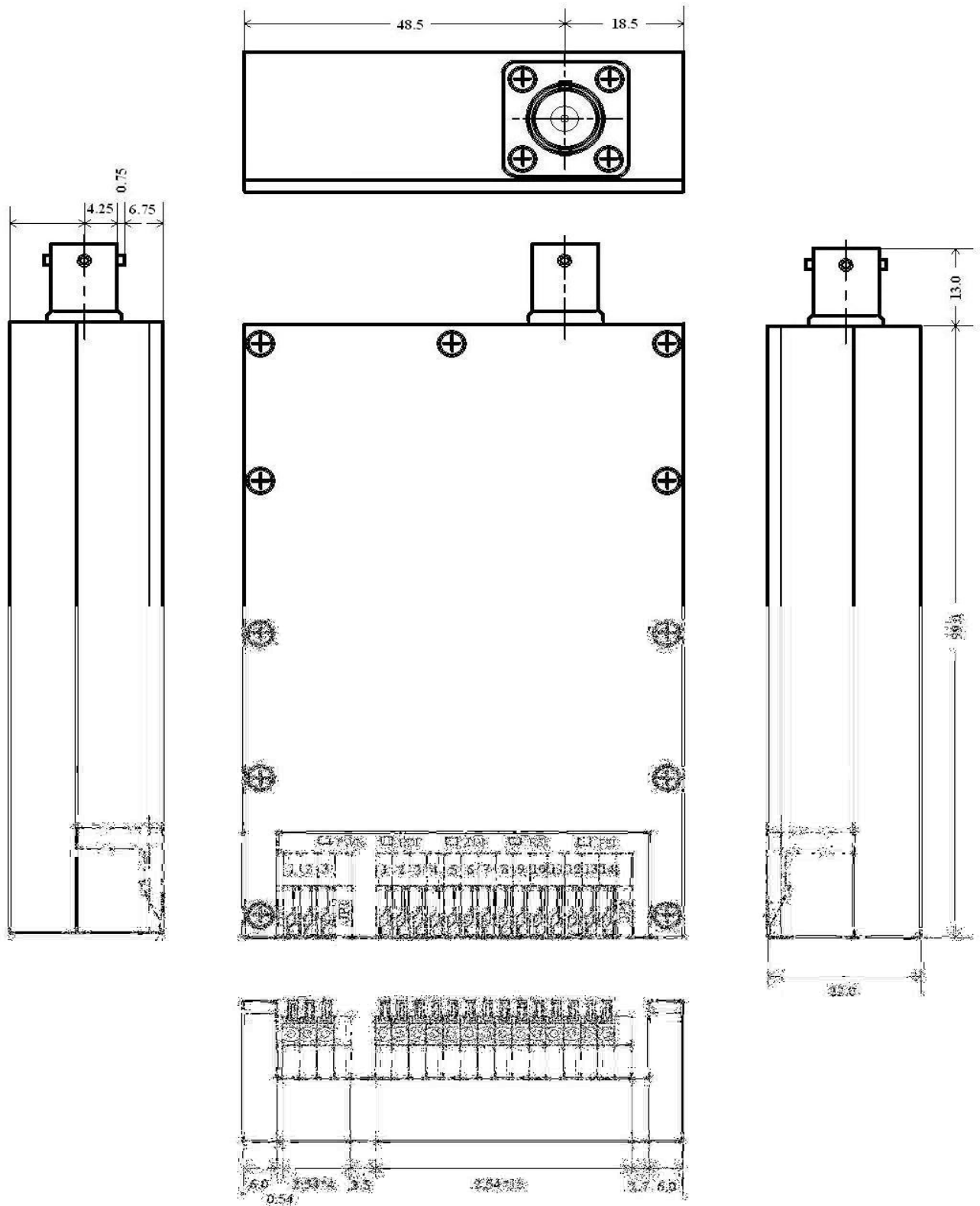

Version B

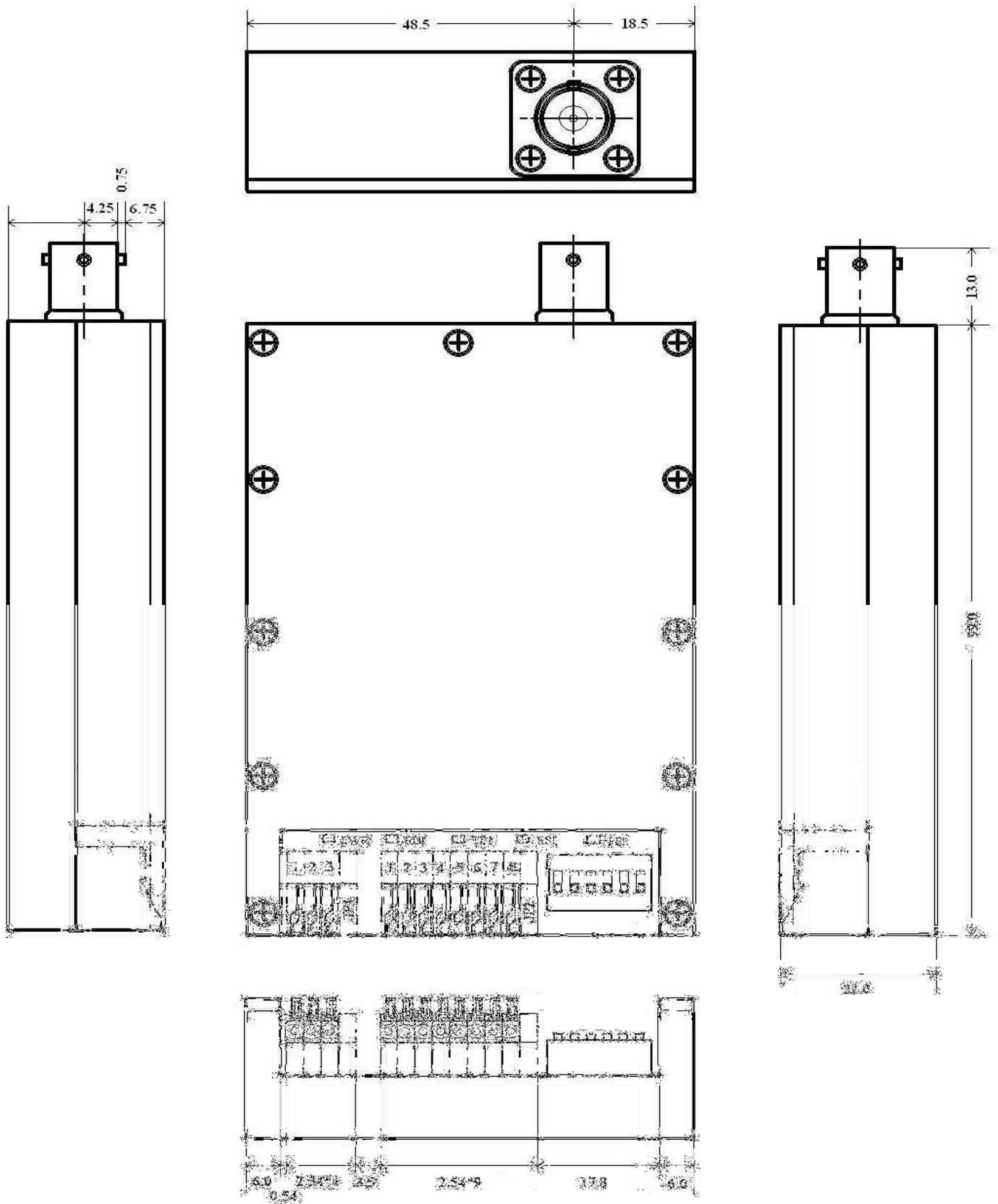
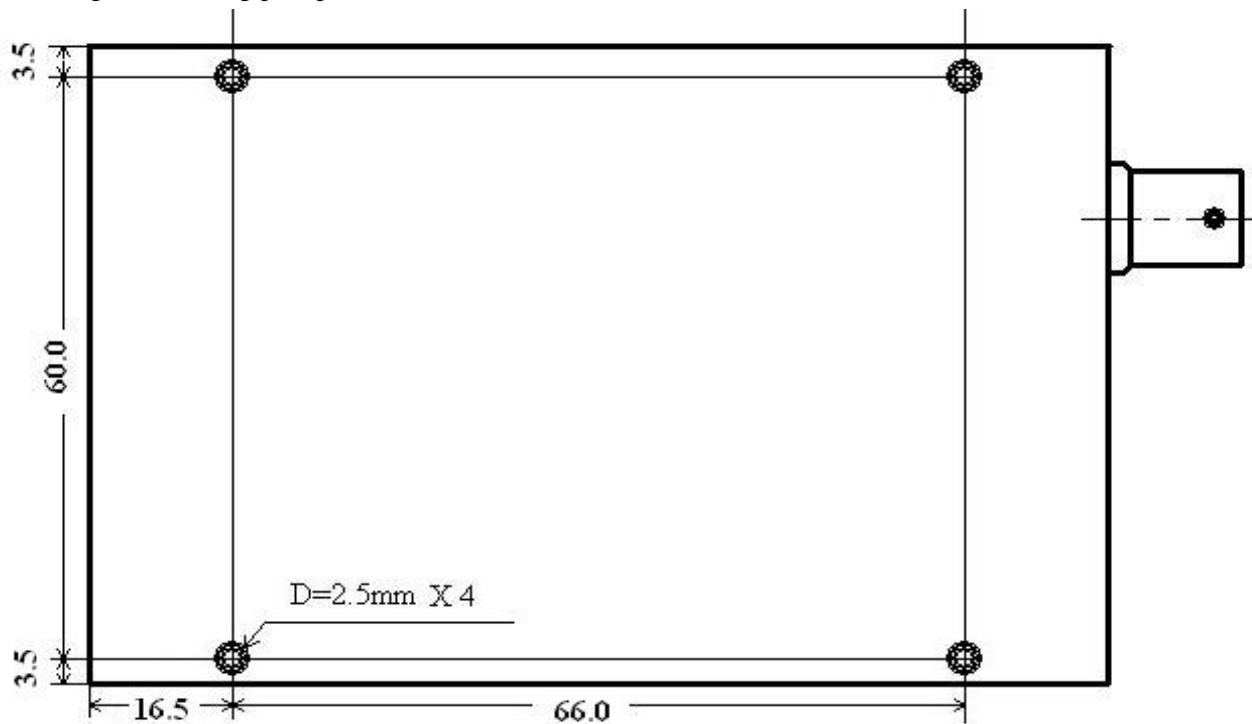

Diagram of fixing pole position:



IV. Networking Application of HAC-HM Series

The communication channel of HAC-HM is semi duplex, which is most suitable for the communication mode of point to multi-point. Under this mode, one master station must be set, and all of the rest are slave stations. A unique address is given to each station. The coordination of communication is controlled by master station that uses data frames containing address code to transmit data or command. Slave station will receive all of the data and command and compare the received address code with local address code. If they are different, the data will be deserted without any response. If those address codes are the same, it means the data is sent to the local. Slave station will make different responses according to the transmitted data or command and send back the data of response. All these jobs must be performed by upper protocol, and it is assured that there is only one transmitter-receiver in the state of transmission in the communication network at any instant moment so as to avoid the cross-interference.

HAC-HM can also be used for point-to-point communication with easier operation. For the programming of serial port, all you have to do is to remember that its communication mode is semi duplex while always observing the time sequence of come-and-go for receiving and transmitting.

. Technical specification of HAC-HM Series

Modulation mode: GFSK

Working frequency: 429~437MHz (customize 402~470MHz)

Frequency stability: $\pm 2.5\text{PPm}$

Transmission power: 5W(37dBm)

2W(33dBm)

Receiving sensitivity: -120dBm@1200bps , -115dBm@9600bps

Channel bandwidth: 100KHZ@9600bps, 12.5KHZ@1200bps

Baud rate: 1200~38400bps (set by factory)

Working temperature: -40 ~80 (industry level)

Transmitting current: 5W 1.3A

2W 800mA

Receiving current: 50mA

Working humidity: 10%~90% relative humidity without condensation

Interface data format: 8E1/8N1

Power supply: +12~16V@1.5A

VI. Fittings

1. Antenna

HAC-HM series uses the BNC antenna connector, it can meet various kinds of antenna requirements. When choosing the antenna, the users must notice the compatibility of the 50 impedance matching and the frequency should be the same. In addition, the antenna can stand the transmission power of 5W.

The standard configuration for HM series doesn't include the antenna. Users can buy the following antenna according to their requirements.

a. Omni-directional fiberglass antenna with high gain



b. Omni-directional big magnetic antenna



c. Directional antenna.



d. Helical antenna with BNC connector



If you use helical antenna with BNC connector, it can not achieve the desired effect transmission. If select a high gain antenna or a directional antenna, fixed outdoor and in a high place, it can greatly enhance the distance.

2. Power line and data line

a. Power line



b. Data line

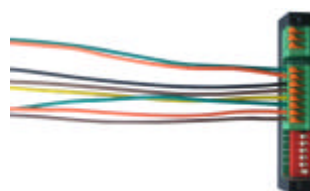



3. Radiator

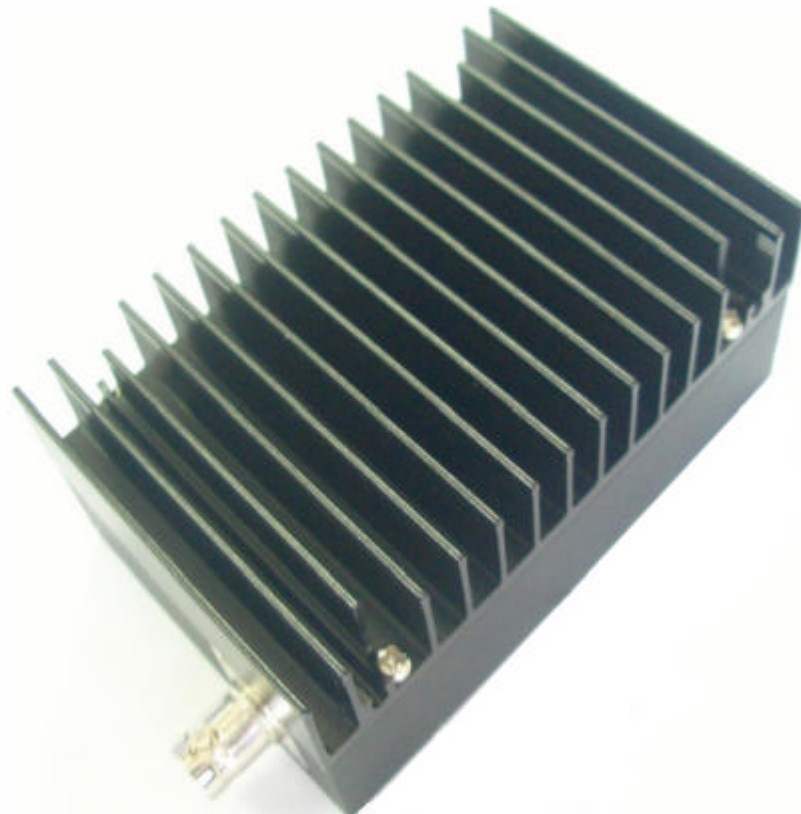



VII. Description of type

HAC-HM-XXX-X-T

HAC - - The name of manufacturer Shenzhen HAC Technology Co., Ltd

HM - - High power data radio

XXX - - Low speed (12), middle speed (96), high speed (384)

X - - 14-pin JP2 (Version A), 8-bit + 6-bit switches JP2 (B)

T - - Radio with radiator

For example: HAC-HM12A-T, HAC-HM12B, HAC-HM96B-T, HAC-HM384B